

DETAILED PARTS AND ASSEMBLY PROCEDURE

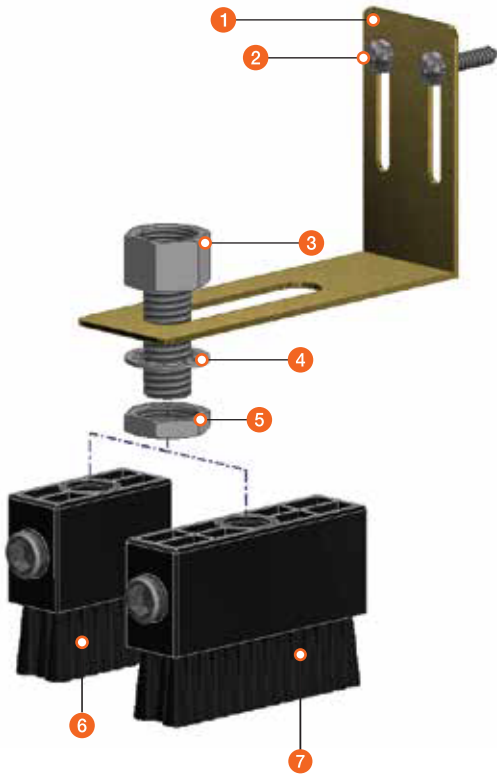

LIST	PART No.	DESCRIPTION	Q'TY
1	B003-01	Oil Brush Bracket, "L" Shape, Steel	1
2	B051	Self Drilling Screw, #8 x 19, Steel	2
3	A315	Reducer, PT3/8" F x PF1/4" Mx30mm x PT1/8" F, Steel	1
4	B058	Tooth Washer, O.D.23mm x I.D.14.5mm x 1t, Steel	1
5	N001	Nut, PF1/4" F x 5mm, Steel	1
6	C017	Oil Brush, 45 x 20 x 30mm Flat Nylon, PF1/4" F	1
7	C018	Oil Brush, 74 x 20 x 30mm Flat Nylon, PF1/4" F	1

ASSEMBLY PROCEDURE

1. Install the Oil Brush Bracket (1) in an appropriate location using the Self Drilling screws (2).
2. Fasten the reducer (3), tooth washer (4), Nut (5) and Pulsarlube OL500 unit in the desired position along the slot of the bracket. The end (3) will connect to an appropriate brush (6) or (7).

COMMENTS

Output volume may vary depending on oil viscosity, ambient temperature, etc.

LIST & PART No.	KIT No.	DESCRIPTION
[1 ~ 5] + 6 (C017)	C044	[OL] 45mm Nylon Flat Oil Brush & Bracket Kit
[1 ~ 5] + 7 (C018)	C045	[OL] 74mm Nylon Flat Oil Brush & Bracket Kit